

1730

MAXIMUS™ HD
LIGHTWEIGHT COMPOSITE

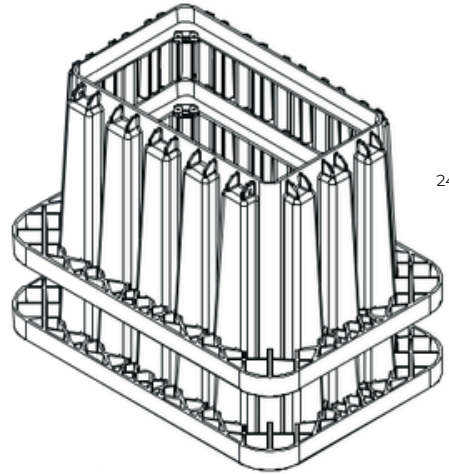
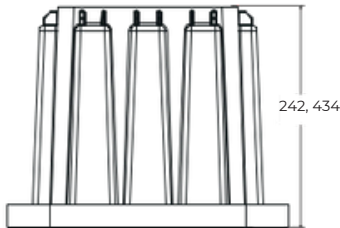
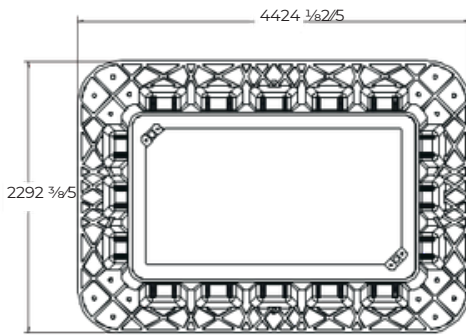
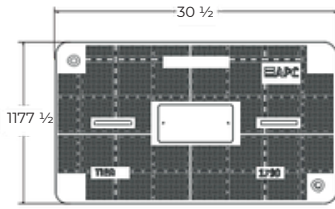

BOLT DOWN OPTIONS

- + HexHead
- + Penta Head
- + Standard Thread
- + Auger Thread

PRODUCT OPTIONS AND ACCESSORIES

- + Knockouts, Mouseholes, and Conduit Entries
- + Cable Racking
- + Dividers
- + EMS Locators
- + Specialty and Security Hardware
- + Grounding and Bonding Accessories

PACKAGING AND SHIPPING

	PALLET QUANTITY	TRUCKLOAD QUANTITY
17" x 30" x 24"	7	294
17" x 30" x 34"	5	210

QUANTITIES LISTED ABOVE ARE FOR UNITS.

PERFORMANCE



All bodies are rated to ANSI/SCTE Tier 22. Overall performance for a unit—defined as a body and cover with bolts—is determined by the lowest-rated component.

Covers are dual-rated to both TIER 15 & TIER 22

MARKING OPTIONS

When it comes to marking plates, **your standard is our standard.** Custom markings and artwork are a breeze to customize your enclosure. Connect with our team for more information on markings.

PRODUCT TYPE	NOMINAL SIZE	PERFORMANCE	PART NUMBER	APPROXIMATE WEIGHT
Unit	17" x 30" x 24"	Tier 15 & Tier 22	CH173024U2299HA	90 lbs.
Unit	17" x 30" x 34"	Tier 15 & Tier 22	CH173034U2299HA	117 lbs.
Box	17" x 30" x 24"	Tier 22	H173024B22	67 lbs.
Box	17" x 30" x 34"	Tier 22	H173034B22	94 lbs.
Cover	17" x 30"	Tier 15 & Tier 22	C1730XXC2200	23 lbs.

Part numbers listed in the table are for standard boxes without accessories. Unit part numbers include an installed marking plate. Units listed above have hex-head, standard thread hardware.

APC PRODUCTS MEET OR EXCEED THE FOLLOWING STANDARDS & GUIDELINES:

- + Build America, Buy America (BABA)
- + Telcordia GR-902-CORE
- + ANSI/SCTE 77 2023
- + Western Underground Committee

The materials and information in this document have been prepared by American Polymer Company for informational purposes only. American Polymer Company reserves the right to make changes or improvements to the products described in this document at anytime without notice. Revision Date: 2/2026

SS-MH173004-0226 © American Polymer Company

